

Volvo B7R

2-axle, RFS, LHD

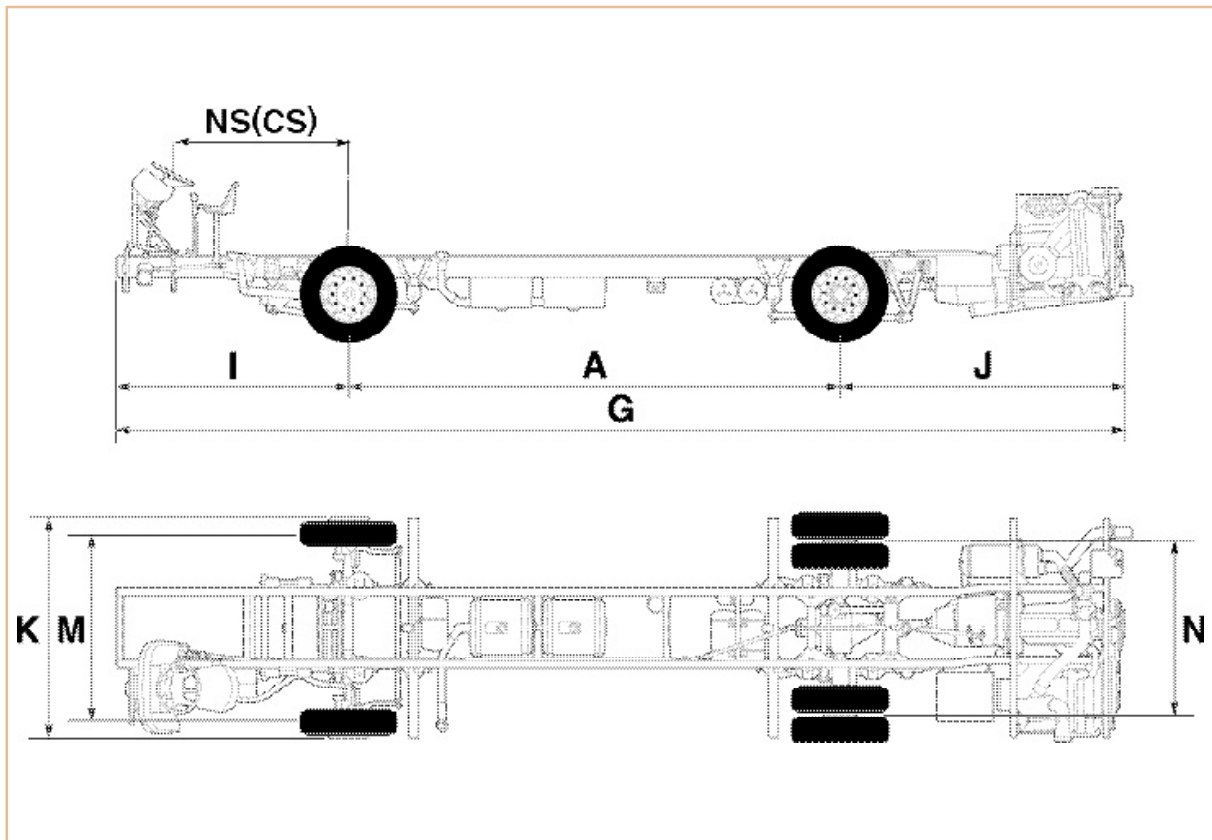

Dimensions & Weight

Overall dimensions

A	Transport wheelbase	3250 mm
	Wheelbase	3250, 4800, 5300 mm
		5500, 6000, 6300 mm
G	Overall chassis length	
	wb 5300	8825 mm
	wb 6300	11875 mm
	Front overhang	2500 mm
J	Rear overhang	3075 mm

	Approach angle	10.5°
	Departure angle	8.0°
	Ground to top of frame at front axle	1008-913 mm
	Ground to top at lowered entry at front door	828-733 mm
X	Ground to top of frame at rear	995-913 mm
	based on tyre 12R22.5"	

	Track width with tyres and steel disc rim	12R22.5" 8.25"x22.5"
M	Track, front	2012 mm
N	Track, rear	1859 mm
K	Overall width front wheels	2440 mm
	Overall width rear wheels	2491 mm

Weights

	Permitted front axle load	6500 kg
	wb 4800	6000 kg
	Permitted rear axle load	11500 kg

wb 4800	10000 kg
Permitted GVW	17500 kg
wb 4800	16000 kg

Driveline - Engine

6-cylinder, 4-stroke diesel with overhead valves and direct injection.
 Bore 104.77 mm
 Stroke 130 mm
 Displacement 6.7 dm³ (l)
 Compression ratio 18:1

D7 230 hp

Output ISO 1585	169 kW (230 hp)
at	36.7 r/s (2200 r/m)
Torque ISO 1585	825 Nm (84 kpm)
at	26.7 r/s (1600 r/m)

D7 260 hp

Output ISO 1585	191 kW (260 hp)
at	36.7 r/s (2200 r/m)
Torque ISO 1585	1100 Nm (112 kpm)
at	21.7 r/s (1300 r/m)

D7 285 hp

Output ISO 1585	210 kW (285 hp)
at	36.7 r/s (2200 r/m)
Torque ISO 1585	1200 Nm (122 kpm)
at	23.3 r/s (1400 r/m)

Fulfil the European emission requirements Euro 2.

D7C

6-cylinders, 4-stroke turbo-charged intercooled diesel with overhead valves and electronically controlled injection.
 Bore 107 mm
 Stroke 35 mm
 Displacement 7.3 liters
 Compression ratio 19.5:1

D7 275 HS/hp

Output ISO 1585	202 kW (275 hp)
at	36.7 r/s (2200 r/m)
Torque ISO 1585	1200 Nm (122 kpm)
at	20.0 r/s (1200 r/m)

D7 290 hp

Output ISO 1585	213 kW (290 hp)
at	36.7 r/s (2200 r/m)
Torque ISO 1585	1200 Nm (122 kpm)
at	18-22 r/s (1100-1320 r/m)

D7 300 hp

Output ISO 1585	224 kW (300 hp)
at	35.1 r/s (2100 r/m)
Torque ISO 1585	1288 Nm (131 kpm)
at	23.3 r/s (1400 r/m)

D7 310 hp

Output ISO 1585	228 kW (310 hp)
at	37 r/s (2200 r/m)
Torque ISO 1585	1350 Nm (138 kpm)
at	20 r/s (1200 r/m)

Fulfil the European emission requirements Euro 3.

Volvo B7R

Fuel tanks

Mounted above front axle	400 l
Mounted in the wheelbase	2x150 l
Mounted front rear axle	300 l
Mounted transport tank	50 l

Clutch

S6-85, Volvo G8-MGS and G8-EGS uses pull type single dry disc KFD116B. Power assisted clutch control gives low pedal pressure.

Diameter	400 mm
Total friction area	1753 cm ²

Optional	Cyclone air filter
Optional	Starter heater
Optional	Water separator

Driveline - Exhaust and Cooling System

Optional	Coolant filter
----------------	----------------

Driveline - Transmission

Transmission

ZF S6-85

Mechanical 6 speed fully synchronized.

Volvo G8-EGS

Esay gear shift. Mechanical 8 speed fully synchronized.

Volvo G8-MGS

Manual 8-speed fully synchronized.

Volvo EGS-VVR

Esay gear shift. Mechanical 8 speed fully synchronized. Without/With Volvo compact retarder.

ZF 4HP500

Fully automatic 4 speed with torque converter.

ZF 5HP550-N

5-speed NBS fully automatic gearbox with integral retarder, electronic control system and neutral bus stop facility.

Voith D863.3

Fully automatic three-stage gearbox with torque converter on first stage. The torque converter also functions as a retarder.

Voith D864.3

ANS - auto neutral at stop. 4 speed fully automatic gearbox with integral retarder and electronic control system. The torque converter also functions as a retarder

	ZF S6-85	Volvo G8-EGS G8-MGS
1st gear	7.72:1	9.13:1
2nd gear	4.42:1	6.42:1
3rd gear	2.85:1	4.77:1
4th gear	1.91:1	3.75:1
5th gear	1.30:1	2.44:1
6th gear	1.00:1	1.71:1
7th gear	-	1.27:1
8th gear	-	1.00:1
Reverse	7.09:1	13.69:1

	Volvo EGS-VVR
1st gear	9.13:1
2nd gear	6.42:1
3rd gear	4.77:1
4th gear	3.75:1
5th gear	2.44:1
6th gear	1.71:1
7th gear	1.27:1
8th gear	1.00:1
Reverse	13.69:1

	ZF 4H500 / ZF 5HP550
Torque converter	2.16:1
1st gear	3.43:1
2nd gear	2.01:1
3rd gear	1.42:1
4th gear	1.00:1
Reverse	4.84:1
Retarder (optional)	0.83:1

	Voith D863.3	Voith D864.3
Hydraulic stage	5.37:1	4.96:1
2nd stage	1.36:1	1.36:1
3rd stage	1.00:1	1.00:1
4th stage	-	0.73:1
Reverse	4.80:1	4.80:1

Driveline - Rear axle and tyres

Rear axle

Single reduction.

Max speed km/h at max engine revs with tyre 295/80R22.5

Ratio:	5.43:1	4.87:1	4.30:1
ZF S6-85	78	87	99
Volvo G8-EGS	78	87	
Volvo G8-MGS	78	87	
ZF 4HP500	78	87	
ZF 5HP550	94	105	
Voith D863.3	78	87	
Voith D864.3	107	119	

Ratio:	4.25:1	3.78:1
ZF S6-85	100	113
Volvo G8-EGS	100	113
Volvo G8-MGS	100	113
ZF 4HP500	100	
Voith D863.3	100	

Tyres & Rims

10-stud steel disc wheels. Dual driving axle wheels.

Rims	Tyres
8.5"x20"	11.00R20"
8.25"x22.5"	12R22.5"
.....	295/80R22.5"

Optional	Spare wheel
----------------	-------------

Suspension and Steering

Rigid front axle suspension.

Numbers	Front	Rear
Air bellows	2	4
Levelling valves	1	2
Stabilizer both front and rear.		
Shock absorbers. Double-acting, hydraulic		

2-axle, RFS, LHD

telescopic shock absorbers, two front, two rear.

Steering gear

Power steering of ball and nut type with built-in servo unit. Approx. 4.5 full turns lock to lock.

Max wheel angle	45°
Steering wheel diameter	500 mm

Air and Brake system

Service brakes

Air brakes complying with EEC regulations with separate circuits for front and rear wheels.

Airdrier. Automatic brake adjustment. Asbestos free brake linings.

Brake lining width:

Front	203 mm
Rear	254 mm

Friction area:

Front axle, drum brake	3055 cm ²
Rear axle, drum brake	3810 cm ²
Total	6865 cm ²

Brake system, operating pressure

..... 7.1-8.3 kp/cm²

Compressor capacity at 8 bar and engine speed 37 r/s (2200 r/m)

..... 8.8 dm³/s (530 l/m)

Compressor ratio

..... 1.46:1

Air tanks standard

- Primary
 - Front circuit
 - Rear circuit
 - Regenerating tank
- Compressed air system can easily be filled from external circuit.

Driveline brake

Electro-pneumatically actuated by pedal switch.

Handbrake

Air operated spring brake acting directly on the rear wheels. Application is infinitely variable by means of a control on the fascia

Optional

Optional

Electric retarder, Telma 191 (S6-85)

Electric retarder, Telma 2200 (G8-MGS)

Hydraulic retarder RET120 (S6-85, ELS-MUX)

Hydraulic retarder RETTH (EGS-VR, ELS-MUX)

Vehicule Structure

Longitudinal members consists of channel sections. Superstructure mounting brackets at front part of chassis.

Frame width	862 mm
Web height, constant	230 mm
Flange width	77 mm
Thickness	6 mm

Optional

Lowered frame (180 mm) at front door for extra instruments.

Volvo B7R

2-axle, RFS, LHD

Driver's seat and Station

Adjustable steering wheel. Self-cancelling direction indicator.

Main dashboard: Indicator lamp panel for; door brake, parking brake, fire alarm, brake pressure, charging, oil pressure, fluid temperature, open door, open hatch, gearbox temperature, coolant temperature, starter heaters, high intensity rear lights, pram service, fans.

Parking brake control, blocking valve, indicator lamp panel and switches for several functions. Switches for starting, voltage feed, stop and cold start, emergency switch for the electrical system, rheostat for instrument lighting. Speedometer with or without tachograf.

Combination instruments 1: Indicator lamps for retarder, split, turn indicator, full headlights, "stopping", two central warning lamps, coolant temperature gauge, fuel gauge, front parking brake gauge, rear parking gauge, tachometer.

Combination instruments 2: Prepared for extra instruments.

Electrical system

Number of batteries 2

Voltage 24 V

Battery capacity 170 Ah

Alternators max output 2x80/80 A

Starter motor 4.5 kW (5.5 hp)

The system also incorporates starter inhibitor relay and one transistor regulator.

Optional Speed limiter

Optional Cruise control